

# SN74ALS990

## 8-BIT D-TYPE TRANSPARENT READ-BACK LATCH

SDAS027B – APRIL 1984 – REVISED JANUARY 1995

- 3-State I/O-Type Read-Back Inputs
- Bus-Structured Pinout
- True Logic Outputs
- Package Options Include Plastic Small-Outline (DW) Packages and Standard Plastic (N) 300-mil DIPs

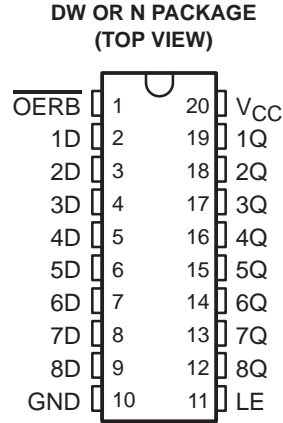

### description

This 8-bit latch is designed specifically for storing the contents of the input data bus and providing the capability of reading back the stored data onto the input data bus.

The eight latches are transparent D-type latches. While the latch-enable (LE) input is high, the Q outputs follow the data (D) inputs.

Read back is provided through the output-enable ( $\overline{\text{OERB}}$ ) input. When  $\overline{\text{OERB}}$  is taken low, the data present at the output of the data latches is allowed to pass back onto the input data bus. When  $\overline{\text{OERB}}$  is taken high, the output of the data latches is isolated from the D inputs.  $\overline{\text{OERB}}$  does not affect the internal operation of the latches; however, precautions should be taken not to create a bus conflict.

The SN74ALS990 is characterized for operation from 0°C to 70°C.

### logic symbol†

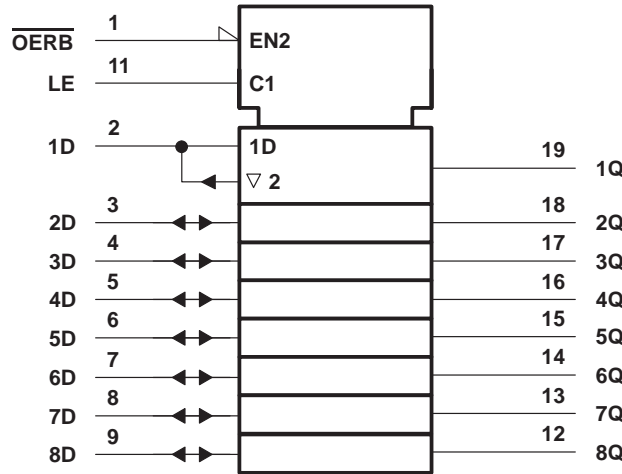

† This symbol is in accordance with ANSI/IEEE Std 91-1984 and IEC Publication 617-12.

# SN74ALS990

## 8-BIT D-TYPE TRANSPARENT READ-BACK LATCH

SDAS027B – APRIL 1984 – REVISED JANUARY 1995

### logic diagram (positive logic)

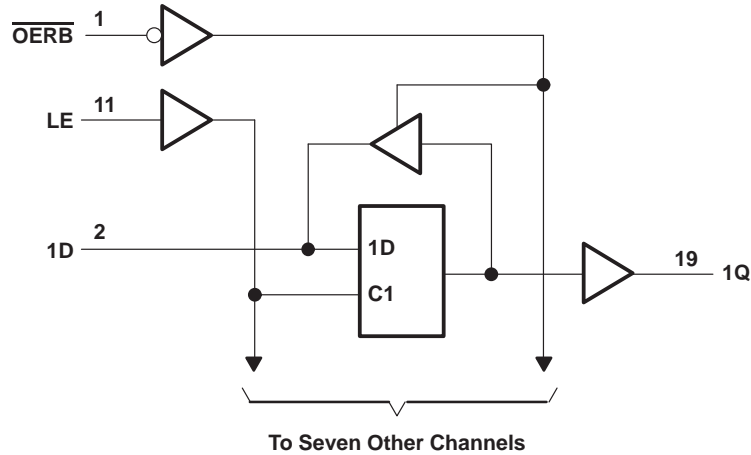

### timing diagram

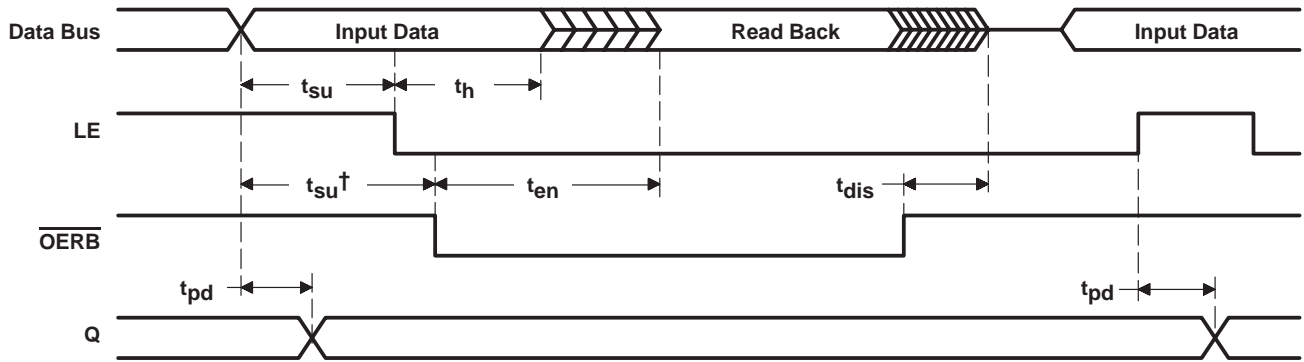

† This setup time ensures that the read-back circuit will not create a conflict on the input data bus.

### absolute maximum ratings over operating free-air temperature range (unless otherwise noted)‡

Supply voltage, $V_{CC}$	7 V
Input voltage, $V_I$ (OERB and LE)	7 V
Voltage applied to D inputs	5.5 V
Operating free-air temperature range, $T_A$	0°C to 70°C
Storage temperature range	-65°C to 150°C

‡ Stresses beyond those listed under "absolute maximum ratings" may cause permanent damage to the device. These are stress ratings only, and functional operation of the device at these or any other conditions beyond those indicated under "recommended operating conditions" is not implied. Exposure to absolute-maximum-rated conditions for extended periods may affect device reliability.

# SN74ALS990

## 8-BIT D-TYPE TRANSPARENT READ-BACK LATCH

SDAS027B – APRIL 1984 – REVISED JANUARY 1995

### recommended operating conditions

		MIN	NOM	MAX	UNIT
$V_{CC}$	Supply voltage	4.5	5	5.5	V
$V_{IH}$	High-level input voltage	2			V
$V_{IL}$	Low-level input voltage			0.8	V
$I_{OH}$	High-level output current	Q		-2.6	mA
		D		-0.4	
$I_{OL}$	Low-level output current	Q		24	mA
		D		8	
$t_w$	Pulse duration, LE high	10			ns
$t_{su}$	Setup time	Data before LE↓	10		ns
		Data before $\overline{OERB}$ ↓	10		
$t_h$	Hold time, data after LE↓	5			ns
$T_A$	Operating free-air temperature	0		70	°C

### electrical characteristics over recommended operating free-air temperature range (unless otherwise noted)

PARAMETER		TEST CONDITIONS		MIN	TYP†	MAX	UNIT
$V_{IK}$		$V_{CC} = 4.5\text{ V}$ ,	$I_I = -18\text{ mA}$			-1.2	V
$V_{OH}$	All outputs	$V_{CC} = 4.5\text{ V to } 5.5\text{ V}$ ,	$I_{OH} = -0.4\text{ mA}$	$V_{CC} - 2$			V
	Q	$V_{CC} = 4.5\text{ V}$ ,	$I_{OH} = -2.6\text{ mA}$	2.4	3.2		
$V_{OL}$	D	$V_{CC} = 4.5\text{ V}$	$I_{OL} = 4\text{ mA}$	0.25	0.4	V	
			$I_{OL} = 8\text{ mA}$	0.35	0.5		
	Q	$V_{CC} = 4.5\text{ V}$	$I_{OL} = 12\text{ mA}$	0.25	0.4		
			$I_{OL} = 24\text{ mA}$	0.35	0.5		
$I_I$	$\overline{OERB}$ , LE	$V_{CC} = 5.5\text{ V}$	$V_I = 5.5\text{ V}$			0.1	mA
	D inputs		$V_I = 7\text{ V}$			0.1	
$I_{IH}$	$\overline{OERB}$ , LE	$V_{CC} = 5.5\text{ V}$ ,	$V_I = 2.7\text{ V}$			20	$\mu\text{A}$
	D inputs‡					20	
$I_{IL}$	$\overline{OERB}$ , LE	$V_{CC} = 5.5\text{ V}$ ,	$V_I = 0.4\text{ V}$			-0.1	mA
	D inputs‡					-0.1	
$I_{O§}$		$V_{CC} = 5.5\text{ V}$ ,	$V_O = 2.25\text{ V}$	-30		-112	mA
$I_{CC}$		$V_{CC} = 5.5\text{ V}$ , $\overline{OERB}$ high	Outputs high		27	50	mA
			Outputs low		40	70	

† All typical values are at  $V_{CC} = 5\text{ V}$ ,  $T_A = 25^\circ\text{C}$ .

‡ For I/O ports ( $Q_A$  thru  $Q_H$ ), the parameters  $I_{IH}$  and  $I_{IL}$  include the off-state output current.

§ The output conditions have been chosen to produce a current that closely approximates one half of the true short-circuit output current,  $I_{OS}$ .

# SN74ALS990

## 8-BIT D-TYPE TRANSPARENT READ-BACK LATCH

SDAS027B – APRIL 1984 – REVISED JANUARY 1995

### switching characteristics (see Figure 1)

PARAMETER	FROM (INPUT)	TO (OUTPUT)	V <sub>CC</sub> = 4.5 V to 5.5 V, C <sub>L</sub> = 50 pF, T <sub>A</sub> = MIN to MAX†		UNIT
			MIN	MAX	
t <sub>PLH</sub>	D	Q	4	17	ns
t <sub>PHL</sub>			5	24	
t <sub>PLH</sub>	LE	Q	6	26	ns
t <sub>PHL</sub>			8	26	
t <sub>en</sub> ‡	$\overline{\text{OERB}}$	D	4	21	ns
t <sub>dis</sub> §	$\overline{\text{OERB}}$	D	4	19	ns

† For conditions shown as MIN or MAX, use the appropriate value specified under recommended operating conditions.

‡ t<sub>en</sub> = t<sub>PZH</sub> or t<sub>PZL</sub>

§ t<sub>dis</sub> = t<sub>PHZ</sub> or t<sub>PLZ</sub>

**PARAMETER MEASUREMENT INFORMATION**

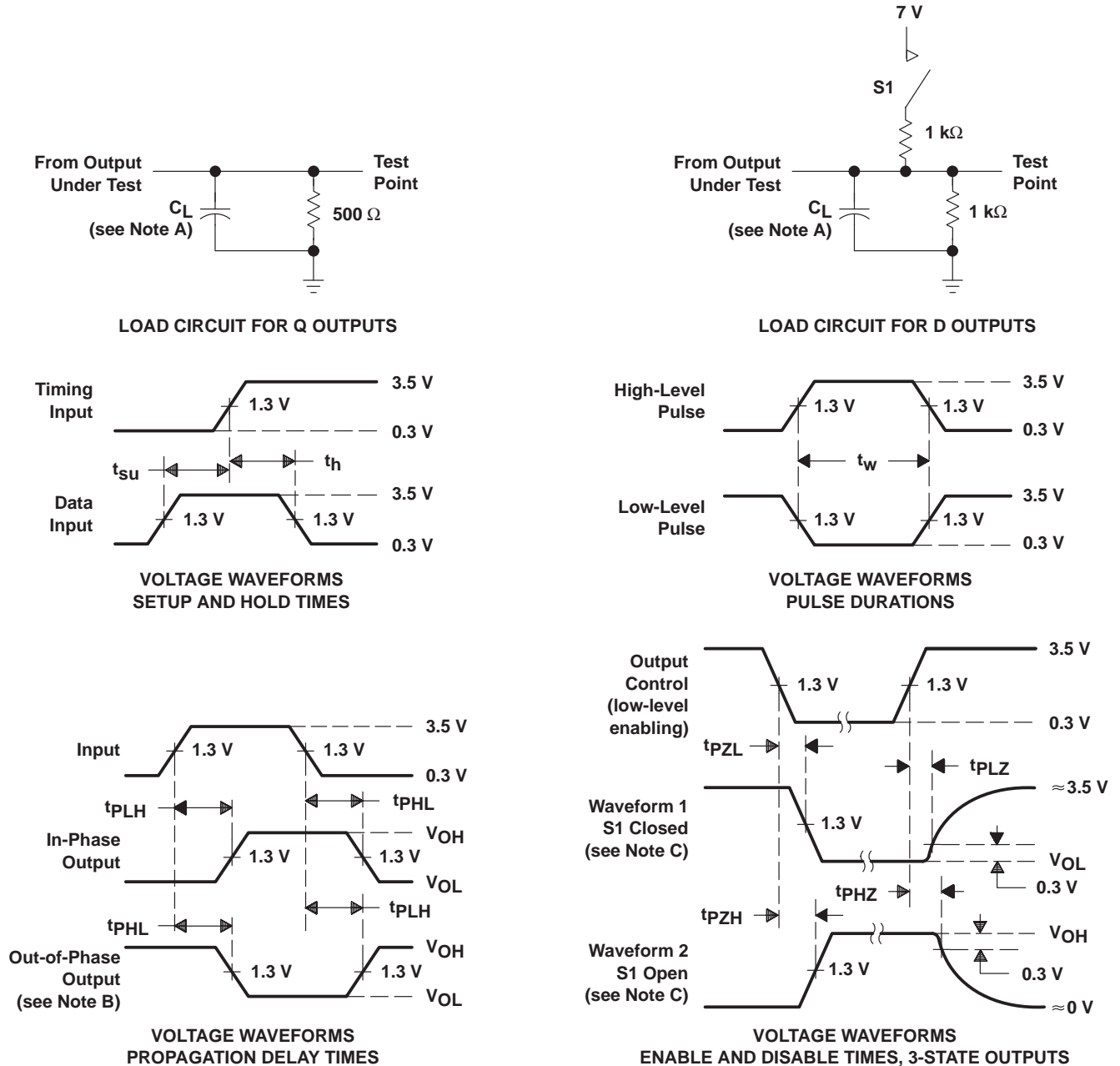

- NOTES: A.  $C_L$  includes probe and jig capacitance.  
 B. When measuring propagation delay times of 3-state outputs, switch S1 is open.  
 C. Waveform 1 is for an output with internal conditions such that the output is low except when disabled by the output control. Waveform 2 is for an output with internal conditions such that the output is high except when disabled by the output control.  
 D. All input pulses have the following characteristics:  $PRR \leq 1 \text{ MHz}$ ,  $t_r = t_f = 2 \text{ ns}$ , duty cycle = 50%.

**Figure 1. Load Circuits and Voltage Waveforms**

**PACKAGING INFORMATION**

Orderable Device	Status <sup>(1)</sup>	Package Type	Package Drawing	Pins	Package Qty	Eco Plan <sup>(2)</sup>	Lead/Ball Finish	MSL Peak Temp <sup>(3)</sup>
SN74ALS990DW	ACTIVE	SOIC	DW	20	25	Green (RoHS & no Sb/Br)	CU NIPDAU	Level-1-260C-UNLIM
SN74ALS990DWE4	ACTIVE	SOIC	DW	20	25	Green (RoHS & no Sb/Br)	CU NIPDAU	Level-1-260C-UNLIM
SN74ALS990DWG4	ACTIVE	SOIC	DW	20	25	Green (RoHS & no Sb/Br)	CU NIPDAU	Level-1-260C-UNLIM
SN74ALS990DWR	ACTIVE	SOIC	DW	20	2000	Green (RoHS & no Sb/Br)	CU NIPDAU	Level-1-260C-UNLIM
SN74ALS990DWRE4	ACTIVE	SOIC	DW	20	2000	Green (RoHS & no Sb/Br)	CU NIPDAU	Level-1-260C-UNLIM
SN74ALS990DWRG4	ACTIVE	SOIC	DW	20	2000	Green (RoHS & no Sb/Br)	CU NIPDAU	Level-1-260C-UNLIM
SN74ALS990N	ACTIVE	PDIP	N	20	20	Pb-Free (RoHS)	CU NIPDAU	N / A for Pkg Type
SN74ALS990N3	OBSOLETE	PDIP	N	20		TBD	Call TI	Call TI
SN74ALS990NE4	ACTIVE	PDIP	N	20	20	Pb-Free (RoHS)	CU NIPDAU	N / A for Pkg Type

<sup>(1)</sup> The marketing status values are defined as follows:

**ACTIVE:** Product device recommended for new designs.

**LIFEBUY:** TI has announced that the device will be discontinued, and a lifetime-buy period is in effect.

**NRND:** Not recommended for new designs. Device is in production to support existing customers, but TI does not recommend using this part in a new design.

**PREVIEW:** Device has been announced but is not in production. Samples may or may not be available.

**OBSOLETE:** TI has discontinued the production of the device.

<sup>(2)</sup> Eco Plan - The planned eco-friendly classification: Pb-Free (RoHS), Pb-Free (RoHS Exempt), or Green (RoHS & no Sb/Br) - please check <http://www.ti.com/productcontent> for the latest availability information and additional product content details.

**TBD:** The Pb-Free/Green conversion plan has not been defined.

**Pb-Free (RoHS):** TI's terms "Lead-Free" or "Pb-Free" mean semiconductor products that are compatible with the current RoHS requirements for all 6 substances, including the requirement that lead not exceed 0.1% by weight in homogeneous materials. Where designed to be soldered at high temperatures, TI Pb-Free products are suitable for use in specified lead-free processes.

**Pb-Free (RoHS Exempt):** This component has a RoHS exemption for either 1) lead-based flip-chip solder bumps used between the die and package, or 2) lead-based die adhesive used between the die and leadframe. The component is otherwise considered Pb-Free (RoHS compatible) as defined above.

**Green (RoHS & no Sb/Br):** TI defines "Green" to mean Pb-Free (RoHS compatible), and free of Bromine (Br) and Antimony (Sb) based flame retardants (Br or Sb do not exceed 0.1% by weight in homogeneous material)

<sup>(3)</sup> MSL, Peak Temp. -- The Moisture Sensitivity Level rating according to the JEDEC industry standard classifications, and peak solder temperature.

**Important Information and Disclaimer:**The information provided on this page represents TI's knowledge and belief as of the date that it is provided. TI bases its knowledge and belief on information provided by third parties, and makes no representation or warranty as to the accuracy of such information. Efforts are underway to better integrate information from third parties. TI has taken and continues to take reasonable steps to provide representative and accurate information but may not have conducted destructive testing or chemical analysis on incoming materials and chemicals. TI and TI suppliers consider certain information to be proprietary, and thus CAS numbers and other limited information may not be available for release.

In no event shall TI's liability arising out of such information exceed the total purchase price of the TI part(s) at issue in this document sold by TI to Customer on an annual basis.

**TAPE AND REEL INFORMATION**



**QUADRANT ASSIGNMENTS FOR PIN 1 ORIENTATION IN TAPE**



\*All dimensions are nominal

Device	Package Type	Package Drawing	Pins	SPQ	Reel Diameter (mm)	Reel Width W1 (mm)	A0 (mm)	B0 (mm)	K0 (mm)	P1 (mm)	W (mm)	Pin1 Quadrant
SN74ALS990DWR	SOIC	DW	20	2000	330.0	24.4	10.8	13.0	2.7	12.0	24.0	Q1

**TAPE AND REEL BOX DIMENSIONS**



\*All dimensions are nominal

Device	Package Type	Package Drawing	Pins	SPQ	Length (mm)	Width (mm)	Height (mm)
SN74ALS990DWR	SOIC	DW	20	2000	346.0	346.0	41.0

DW (R-PDSO-G20)

PLASTIC SMALL-OUTLINE PACKAGE



- NOTES:
- A. All linear dimensions are in inches (millimeters).
  - B. This drawing is subject to change without notice.
  - C. Body dimensions do not include mold flash or protrusion not to exceed 0.006 (0,15).
  - D. Falls within JEDEC MS-013 variation AC.

N (R-PDIP-T\*\*)

PLASTIC DUAL-IN-LINE PACKAGE

16 PINS SHOWN



4040049/E 12/2002

- NOTES:
- A. All linear dimensions are in inches (millimeters).
  - B. This drawing is subject to change without notice.
  - Falls within JEDEC MS-001, except 18 and 20 pin minimum body length (Dim A).
  - The 20 pin end lead shoulder width is a vendor option, either half or full width.

## IMPORTANT NOTICE

Texas Instruments Incorporated and its subsidiaries (TI) reserve the right to make corrections, modifications, enhancements, improvements, and other changes to its products and services at any time and to discontinue any product or service without notice. Customers should obtain the latest relevant information before placing orders and should verify that such information is current and complete. All products are sold subject to TI's terms and conditions of sale supplied at the time of order acknowledgment.

TI warrants performance of its hardware products to the specifications applicable at the time of sale in accordance with TI's standard warranty. Testing and other quality control techniques are used to the extent TI deems necessary to support this warranty. Except where mandated by government requirements, testing of all parameters of each product is not necessarily performed.

TI assumes no liability for applications assistance or customer product design. Customers are responsible for their products and applications using TI components. To minimize the risks associated with customer products and applications, customers should provide adequate design and operating safeguards.

TI does not warrant or represent that any license, either express or implied, is granted under any TI patent right, copyright, mask work right, or other TI intellectual property right relating to any combination, machine, or process in which TI products or services are used. Information published by TI regarding third-party products or services does not constitute a license from TI to use such products or services or a warranty or endorsement thereof. Use of such information may require a license from a third party under the patents or other intellectual property of the third party, or a license from TI under the patents or other intellectual property of TI.

Reproduction of TI information in TI data books or data sheets is permissible only if reproduction is without alteration and is accompanied by all associated warranties, conditions, limitations, and notices. Reproduction of this information with alteration is an unfair and deceptive business practice. TI is not responsible or liable for such altered documentation. Information of third parties may be subject to additional restrictions.

Resale of TI products or services with statements different from or beyond the parameters stated by TI for that product or service voids all express and any implied warranties for the associated TI product or service and is an unfair and deceptive business practice. TI is not responsible or liable for any such statements.

TI products are not authorized for use in safety-critical applications (such as life support) where a failure of the TI product would reasonably be expected to cause severe personal injury or death, unless officers of the parties have executed an agreement specifically governing such use. Buyers represent that they have all necessary expertise in the safety and regulatory ramifications of their applications, and acknowledge and agree that they are solely responsible for all legal, regulatory and safety-related requirements concerning their products and any use of TI products in such safety-critical applications, notwithstanding any applications-related information or support that may be provided by TI. Further, Buyers must fully indemnify TI and its representatives against any damages arising out of the use of TI products in such safety-critical applications.

TI products are neither designed nor intended for use in military/aerospace applications or environments unless the TI products are specifically designated by TI as military-grade or "enhanced plastic." Only products designated by TI as military-grade meet military specifications. Buyers acknowledge and agree that any such use of TI products which TI has not designated as military-grade is solely at the Buyer's risk, and that they are solely responsible for compliance with all legal and regulatory requirements in connection with such use.

TI products are neither designed nor intended for use in automotive applications or environments unless the specific TI products are designated by TI as compliant with ISO/TS 16949 requirements. Buyers acknowledge and agree that, if they use any non-designated products in automotive applications, TI will not be responsible for any failure to meet such requirements.

Following are URLs where you can obtain information on other Texas Instruments products and application solutions:

### Products

Amplifiers	<a href="http://amplifier.ti.com">amplifier.ti.com</a>
Data Converters	<a href="http://dataconverter.ti.com">dataconverter.ti.com</a>
DSP	<a href="http://dsp.ti.com">dsp.ti.com</a>
Clocks and Timers	<a href="http://www.ti.com/clocks">www.ti.com/clocks</a>
Interface	<a href="http://interface.ti.com">interface.ti.com</a>
Logic	<a href="http://logic.ti.com">logic.ti.com</a>
Power Mgmt	<a href="http://power.ti.com">power.ti.com</a>
Microcontrollers	<a href="http://microcontroller.ti.com">microcontroller.ti.com</a>
RFID	<a href="http://www.ti-rfid.com">www.ti-rfid.com</a>
RF/IF and ZigBee® Solutions	<a href="http://www.ti.com/lprf">www.ti.com/lprf</a>

### Applications

Audio	<a href="http://www.ti.com/audio">www.ti.com/audio</a>
Automotive	<a href="http://www.ti.com/automotive">www.ti.com/automotive</a>
Broadband	<a href="http://www.ti.com/broadband">www.ti.com/broadband</a>
Digital Control	<a href="http://www.ti.com/digitalcontrol">www.ti.com/digitalcontrol</a>
Medical	<a href="http://www.ti.com/medical">www.ti.com/medical</a>
Military	<a href="http://www.ti.com/military">www.ti.com/military</a>
Optical Networking	<a href="http://www.ti.com/opticalnetwork">www.ti.com/opticalnetwork</a>
Security	<a href="http://www.ti.com/security">www.ti.com/security</a>
Telephony	<a href="http://www.ti.com/telephony">www.ti.com/telephony</a>
Video & Imaging	<a href="http://www.ti.com/video">www.ti.com/video</a>
Wireless	<a href="http://www.ti.com/wireless">www.ti.com/wireless</a>

Mailing Address: Texas Instruments, Post Office Box 655303, Dallas, Texas 75265  
Copyright © 2008, Texas Instruments Incorporated